



PIVOT 38
WINDOW (38mm)

General Documentation Disclaimer

This manual is intended as a manufacturing and installation advisory document. For correct specifications, sizing of profiles and structural information please consult the StarFront Application. If the information you require is not available through the StarFront Application, please contact your stockist before proceeding. It is advisable to have all sizing and performance criteria checked by a qualified structural engineer to ensure that the required criteria will be met.

All information, recommendations or advice contained in this documentation is given in good faith to the best of Wispeco's knowledge and is based on current procedures in effect.

Since the actual use of this documentation by the user is beyond the control of Wispeco, such use is within the exclusive responsibility of the user. Wispeco cannot be held responsible for any loss incurred through incorrect or faulty use of this documentation. Training of Wispeco systems is important for ensuring correct procedures in the manufacturing of products.

Great care has been taken to ensure that the information provided is correct.

Ensure that you have the latest available manual. The revision number and date can be checked on the latest StarFront version.

Wispeco will accept no responsibility for any errors and/or omissions, which may have inadvertently occurred.

Specifications concerning products and applications

This manual is based on standard configurations only. As there are many configurations not covered in this manual, contact your stockist with regards to a configuration not represented herein if required.

AutoDesk drawings (CAD Symbol Library) are available on request and can be issued with the consent of the Wispeco Technical Department.

All mechanical joints must be sealed with a **Crealco approved joint sealer**. Failure to correctly seal the joints can affect the performance of the system. Information on joint sealing can be found in the Cleaning & Maintenance Manual available for download from the Wispeco website or from StarFront.

All drawings in the Wispeco Documentation are NOT to scale and are used for illustrative purposes only.

Wispeco will not accept responsibility for the use of standard products since Wispeco does not know where these products are being installed.

The hardware recommended in this documentation is suitable for use in most atmospheric environments. When hardware is used in severe coastal environments the manufacturer of the hardware must be consulted.

The use of non-specified hardware or incorrect mechanical fasteners can adversely affect the mechanical and weathering performance of the system and we strongly advise against deviations. A Wispeco Consultant can advise you of any hardware issues and limitations with regard to this system.

The use of anti-magnetic stainless steel screws and aluminium pop rivets is recommended to reduce galvanic corrosion in harsh environments.

Fixing lugs on frames must be positioned as per the user manual and used in accordance to the AAMSA specifications. When profiles are screwed together the screw centres must also be according to the user manual or as specified by an engineer.

All glass used within Wispeco products must comply with SAGGA regulations. Laminated glass must not stand in water.

By continuing to use this documentation you acknowledge that you understand and accept the legal disclaimer.

This manual must be read in conjunction with the Installation, Cleaning & Maintenance Document and the Performance Certificates for the relevant system. The manual must also be used in conjunction with the design and cutting list from the latest version of StarFront.

Index ii
Legal Disclaimer..... 1

General System

Profile Identification..... 2
Hardware Components 3
Butterfly Gasket & Wedge Codes..... 4
Window Fixing Details..... 5
Setting Block Location..... 6-7
Sash Limitation Chart..... 8
Cross Sectional Detail.....
 Vertical Opening..... 9
 Horizontal Opening 10
 Vertical Frame..... 11
 Horizontal Frame..... 12
Component Assembly Detail.....
 Pivot Frame..... 13
 Pivot Sash..... 14
Sash Installation Detail..... 15
Siliconing Seal of Finseal..... 16
Fixing of Corner Cleats on Pivot Sash 17
Sill Drainage Detail..... 18-19
Sill Level Detail..... 20-21
Machining Detail.....
 Head & Sill..... 22
 Frame Friction..... 23
 Sash Friction..... 24
 Pivot Sash Handle..... 25
Glazing Procedure..... 26-27

PIVOT 38
WINDOW (38mm)



This manual must be read in conjunction with the Installation, Cleaning & Maintenance Document and the Performance Certificates for the relevant system. The manual must also be used in conjunction with the design and cutting list from the latest version of StarFront.

Profile Identification

Clip38 Pivot Profiles

Note: StarFront can only do single glazing configurations at the moment, for double glazing panels please see chart as shown.



DIE No. W31141

Clip38 38B Bevel
Bead 4mm-6mm



DIE No. W30468

Clip38 38SB Bevel
Bead 8mm-10mm



DIE No. W70214

Clip38 28S Square
Bead 4mm-6mm

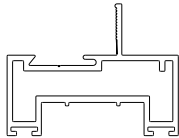

DIE No. W54787

Clip38 PW1
Pivot Sash

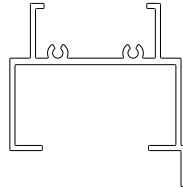

DIE No. W70222

Clip38 PW2
Pivot Frame

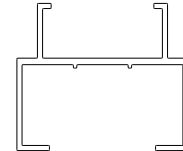

DIE No. W70223

Clip38 PW3
Pivot Frame



DIE No. W32041

Clip38 DG Bead
Double Glazing

Hardware Components

RECOMMENDED CLIP38 PIVOT COMPONENTS

All hardware is available through our Stockists as well as through Crealco Components, and can be viewed on www.crealco-components.com

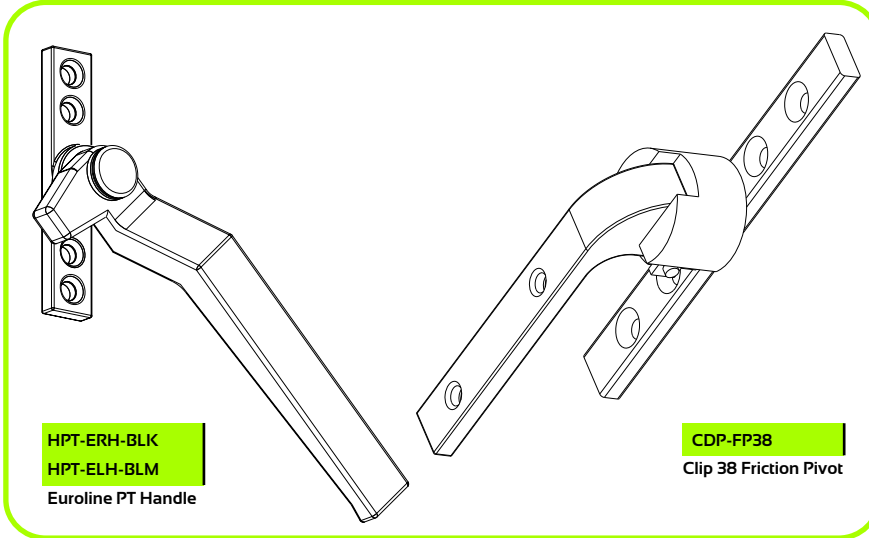

HPT-ERH-BLK
HPT-ELH-BLM
Euroline PT Handle

CDP-FP38
Clip 38 Friction Pivot

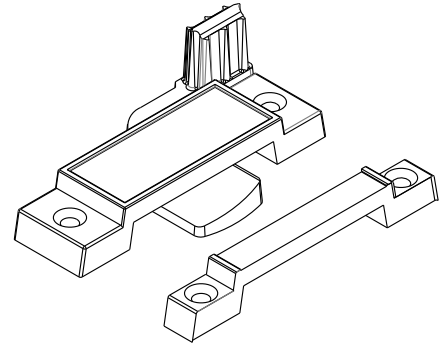

HCC-FCK
Fitch Catch

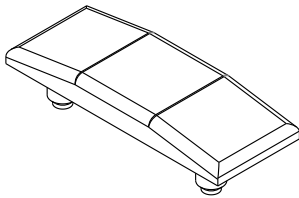

HPT-WG-BLK
Wedge For PT Handle

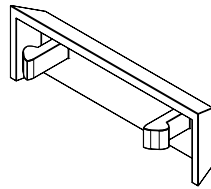

PEX-WDC
Weephole Cover

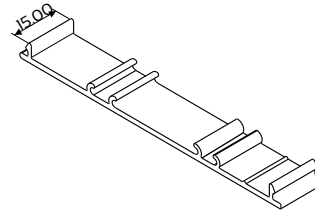

W30607
Multi Fixing Lug Alum 15mm

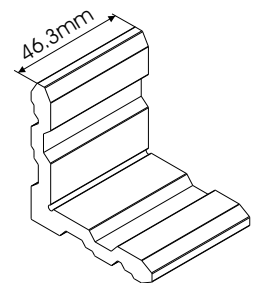

W24919
Corner Cleat 46.3mm

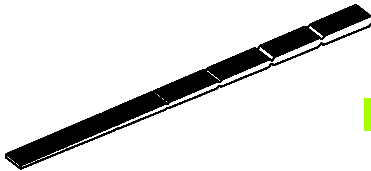

FSN-GSB
Glass Setting Blocks

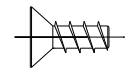

FSC-0809HBP
8x9 C/S Handle Screw Blunt Point

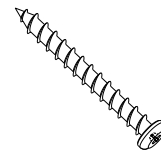

FSP-0840P-SS
P/Head POSI 8x40 S/S Screw

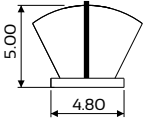
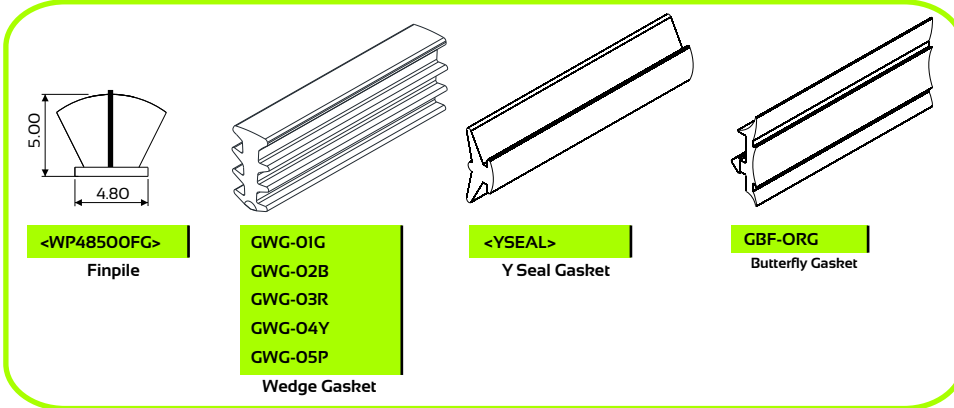

<WP48500FG>
Finpile

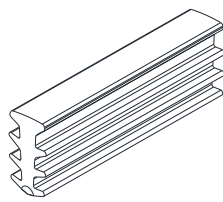

GWG-01G
GWG-02B
GWG-03R
GWG-04Y
GWG-05P
Wedge Gasket

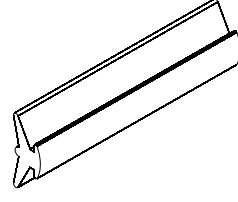

<YSEAL>
Y Seal Gasket

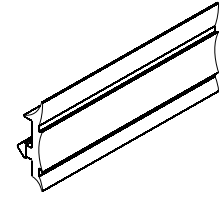

GBF-ORG
Butterfly Gasket

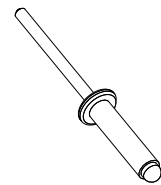

FRC-4812
Dome Rivet 4.8x10mm



**BUTTERFLY GASKET
B010**

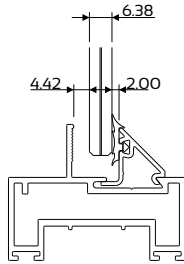

**CLIP38 ANGLED BEAD 13mm GAP
W31141**

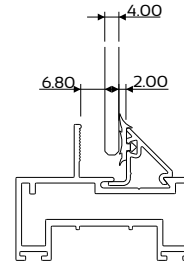
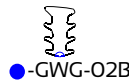
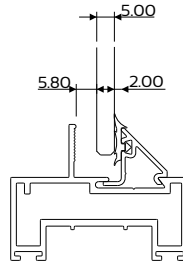

**BUTTERFLY GASKET
GBF-ORG**

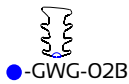
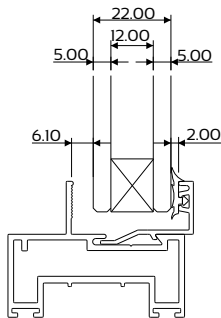

**BEAD DOUBLE GLAZING
W32041**

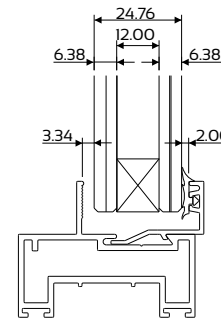
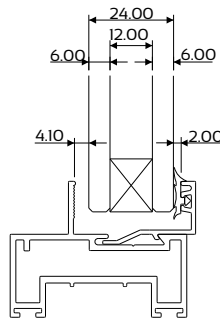

**BUTTERFLY GASKET BEAD DOUBLE GLAZING
GBF-ORG W32041**

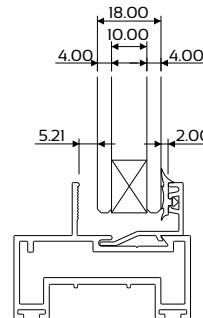
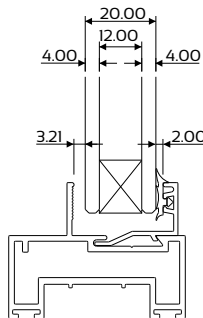

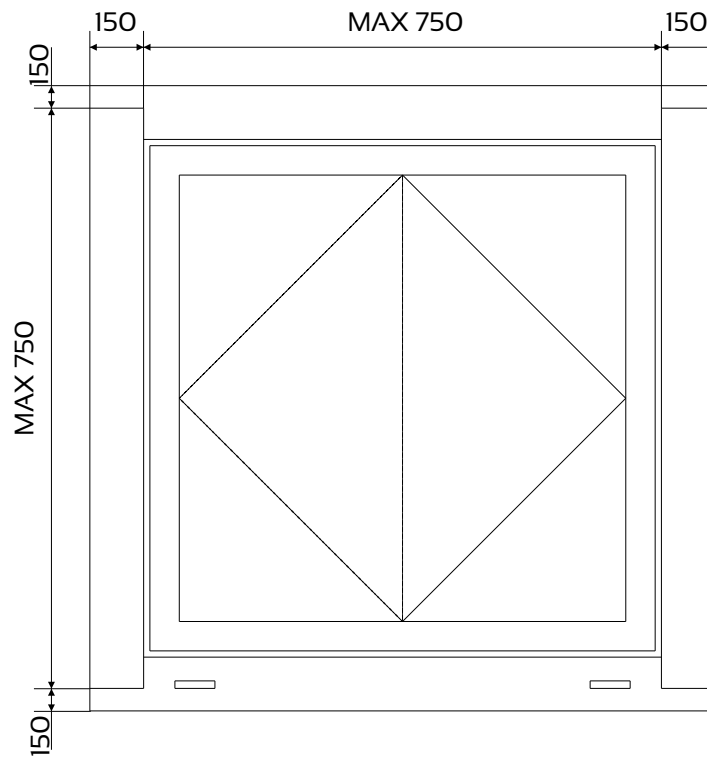

All glazing methods require setting and location blocks as illustrated below to ensure proper performance of all elements of the finished products.

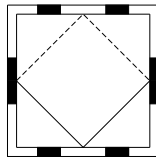

Horizontally Pivoted

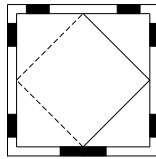

Vertically Pivoted
Hung Centrally

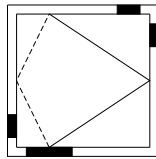

Vertically Pivoted
Hung Off Centre

POSITION OF SETTING AND LOCATION BLOCKS
AS RECOMMENDED BY
SOUTH AFRICAN STANDARD - SABS 0137-1984
CODE OF PRACTISE FOR
THE INSTALLATION OF GLAZING MATERIALS IN BUILDINGS

GLAZING

1. SELECTION OF GLAZING METHODS

1.1 SETTING AND LOCATION BLOCKS

Glass-to-metal contact must be avoided at all times by using setting and location blocks having a hardness of 50° to 90° shore A durometer. Use only blocks made of Neoprene, EPDM, Silicone or other elastomeric material.

Setting blocks are to have a minimum thickness of 3mm and must be at least 27mm in length per square metre of glass area.

In the event of laminated glass and/or sealed insulated glass units drainage is to be provided to prevent the glass edge to be submerged. Two or more 7mm diameter holes or 5mm x 9mm slotted holes, or larger, are to be equally spaced in the sill section of sash or frame to allow for such ventilation/drainage.

The position of the setting and location blocks is illustrated in Figure 2.

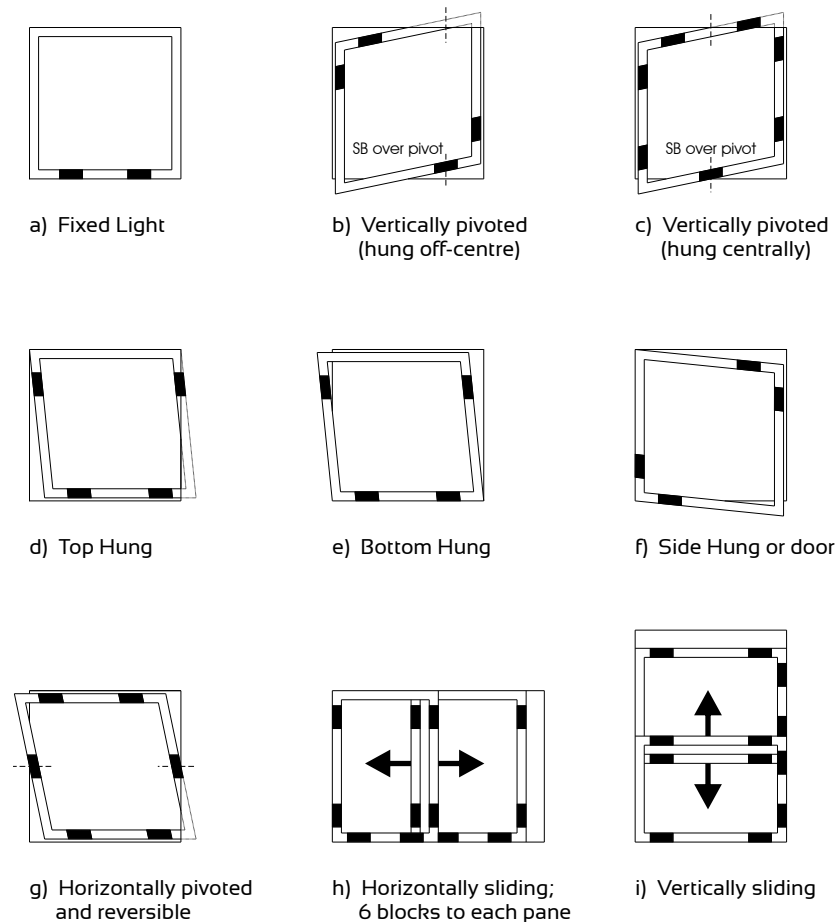
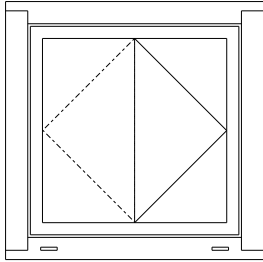
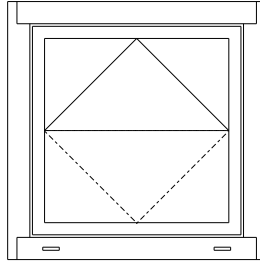

FIGURE 2 - POSITION OF SETTING AND LOCATION BLOCKS

VERTICAL PIVOT WINDOW



HORIZONTAL PIVOT WINDOW



VERTICAL PIVOT WINDOW
IN SHOPFRONT FRAME

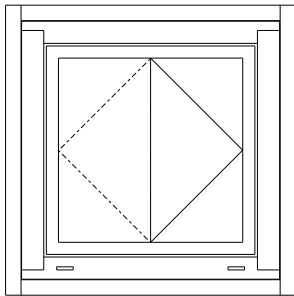

HORIZONTAL PIVOT WINDOW
IN SHOPFRONT FRAME

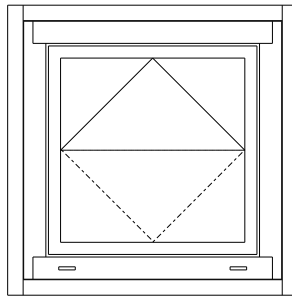

————— OPEN IN

- - - - - OPEN OUT

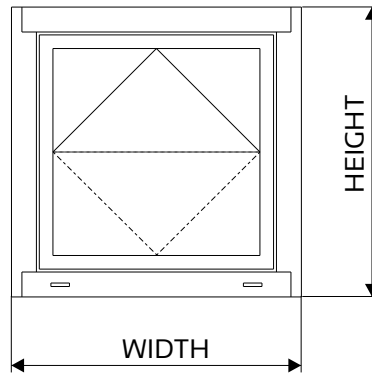
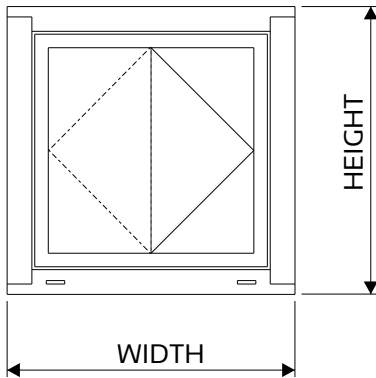

	Maximum Vent Width in mm	Maximum Vent Height in mm
PIVOT SASH W54787	1200	1500

*** USE 2 HANDLES AND 2 FITCH CATCHES ON SASH OVER 900 mm WIDE**



This manual must be read in conjunction with the Installation, Cleaning & Maintenance Document and the Performance Certificates for the relevant system. The manual must also be used in conjunction with the design and cutting list from the latest version of StarFront.

Cross Sectional Detail

Vertical Opening

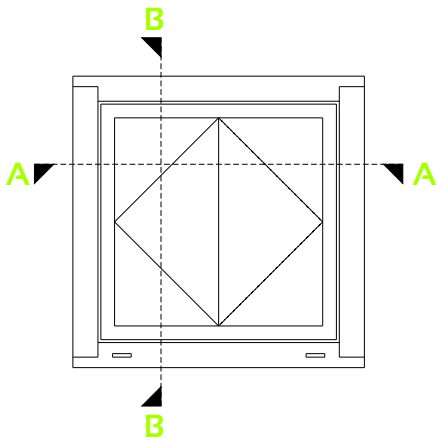

SECTION B-B
Section not to scale

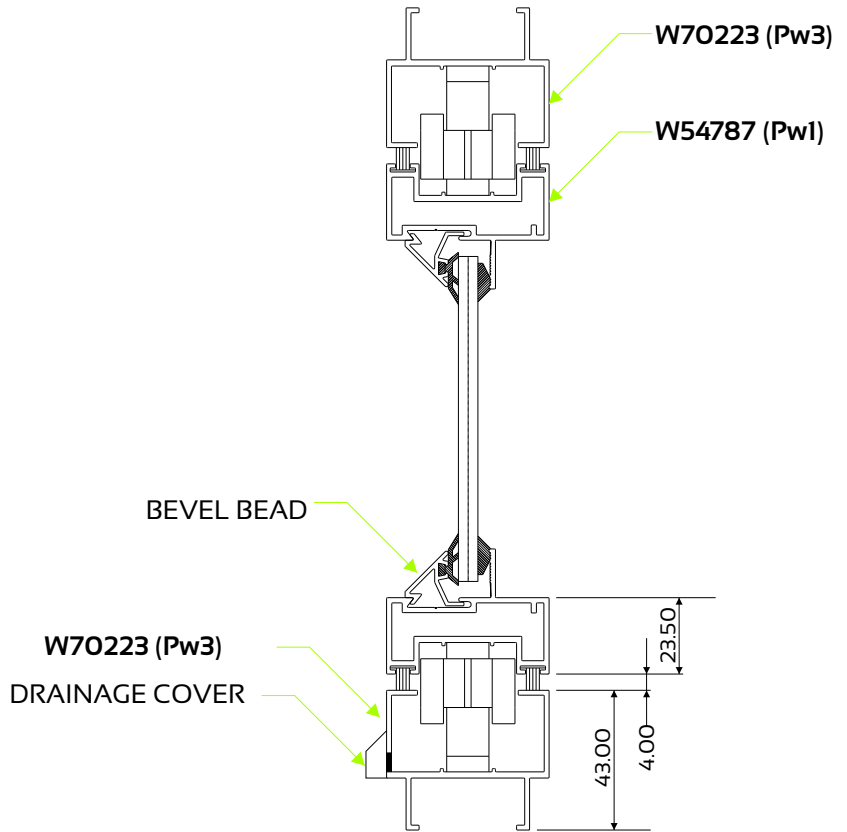

SECTION A-A
Section not to scale

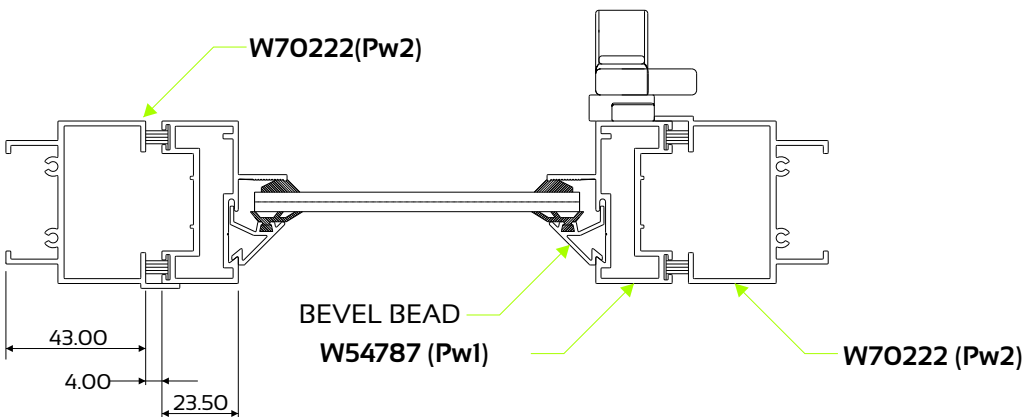

Cross Sectional Detail

Horizontal Opening

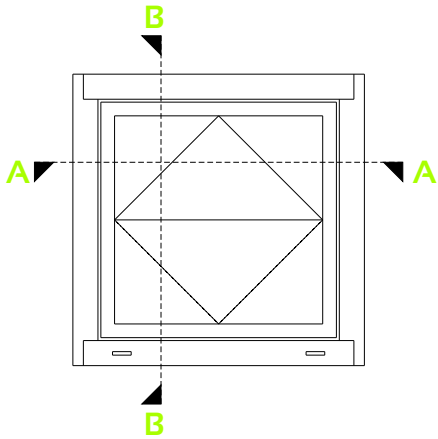

SECTION B-B
Section not to scale

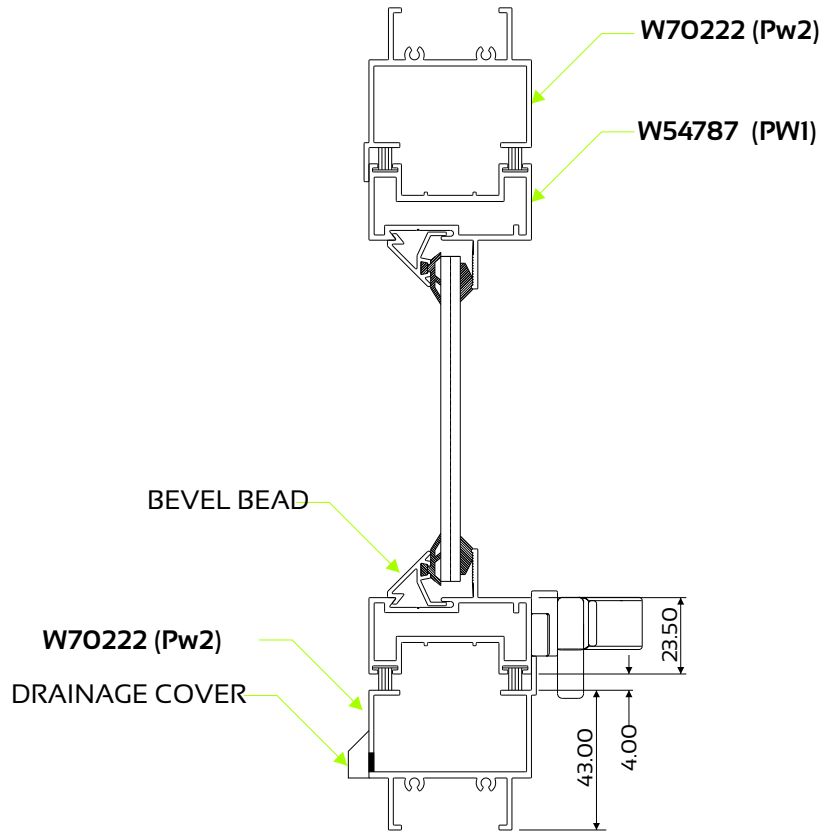

SECTION A-A
Section not to scale

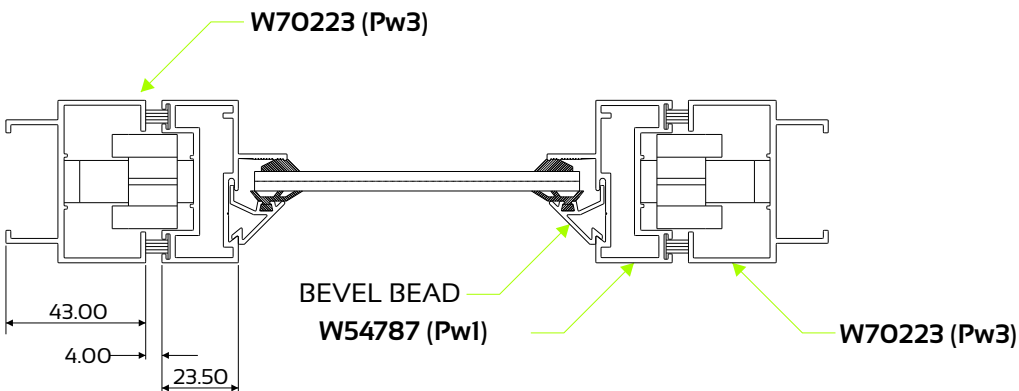

Cross Sectional Detail

Vertical Frame

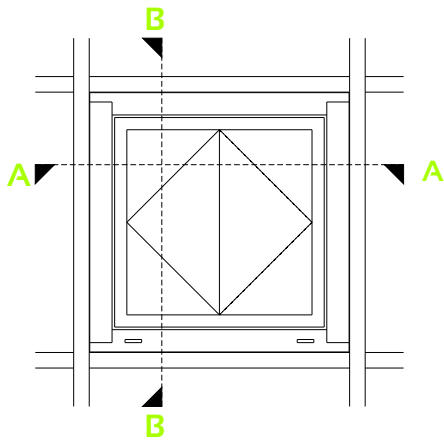

SECTION B-B
Section not to scale

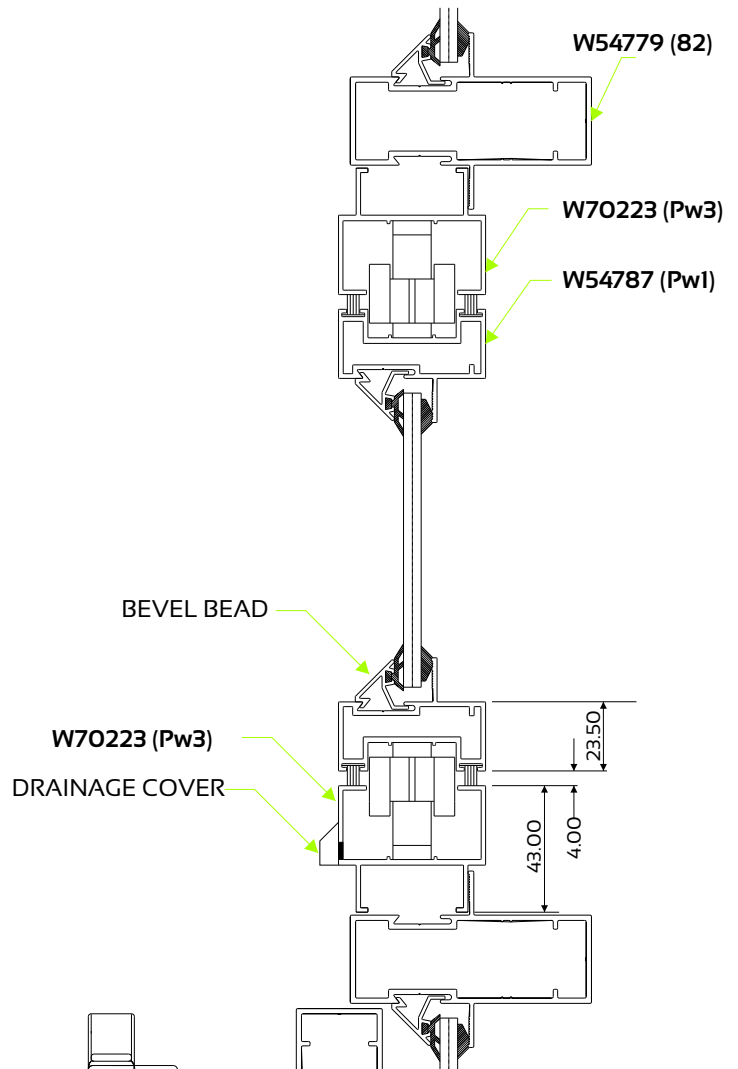

SECTION A-A
Section not to scale

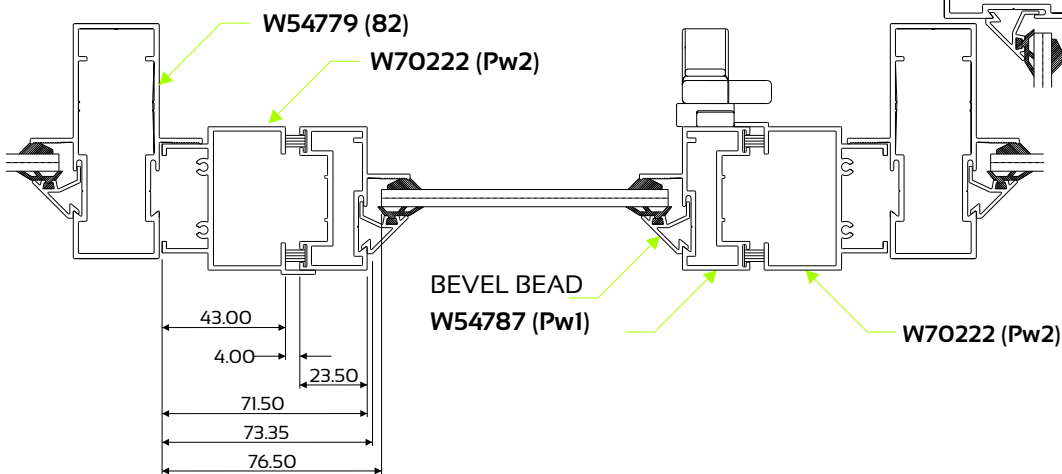

This manual must be read in conjunction with the Installation, Cleaning & Maintenance Document and the Performance Certificates for the relevant system. The manual must also be used in conjunction with the design and cutting list from the latest version of StarFront.

Cross Sectional Detail

Horizontal Frame

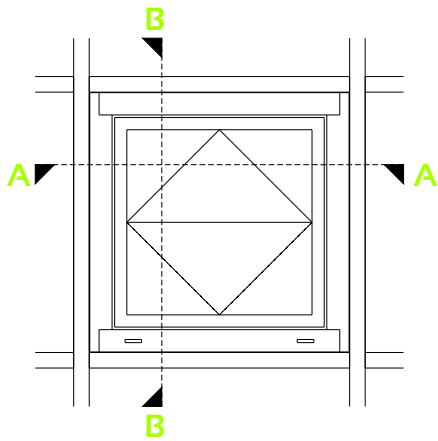

SECTION B-B
Section not to scale

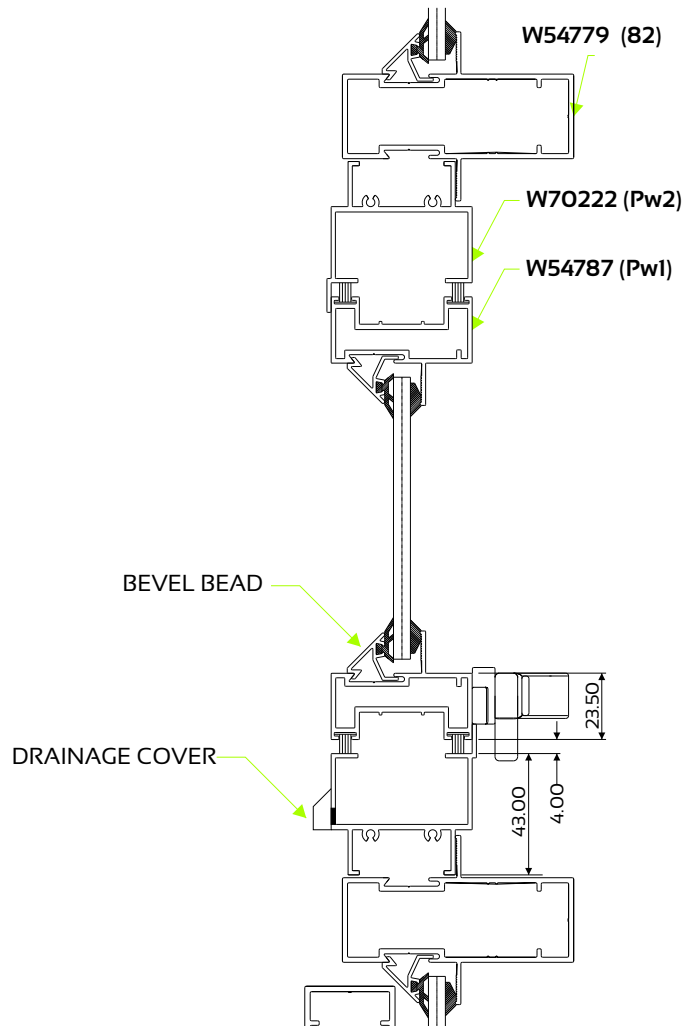

SECTION A-A
Section not to scale

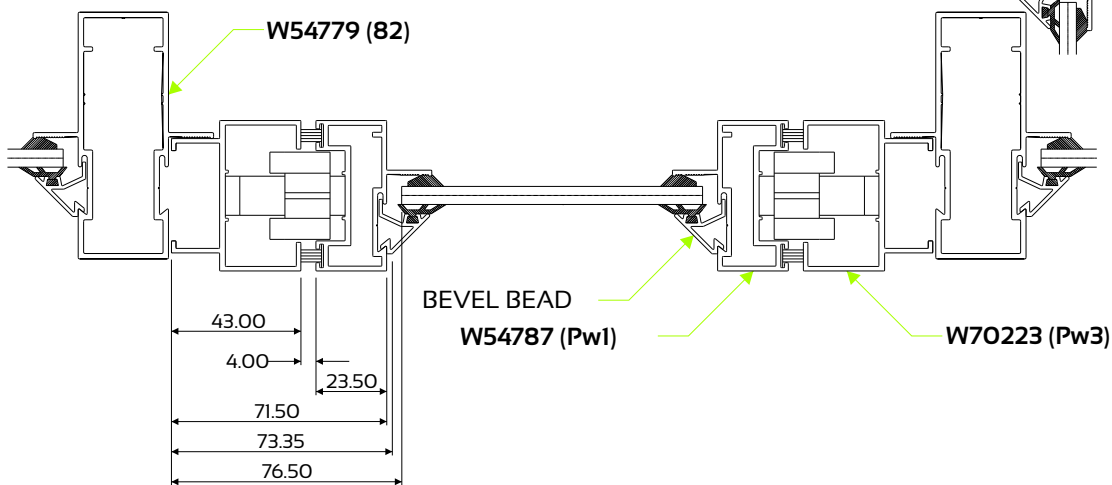

This manual must be read in conjunction with the Installation, Cleaning & Maintenance Document and the Performance Certificates for the relevant system. The manual must also be used in conjunction with the design and cutting list from the latest version of StarFront.

Component Assembly Detail

Pivot Frame

Add centre drainage hole and covers on widths over 700mm

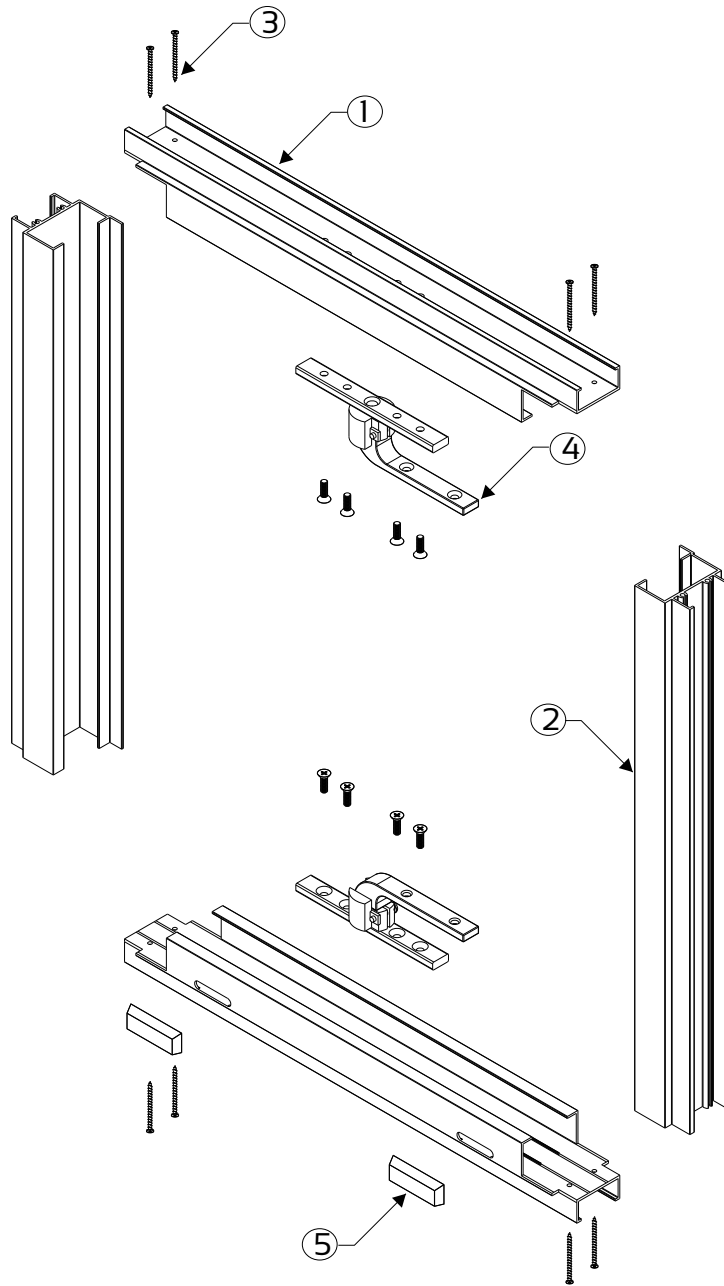

System Profiles

ITEM	QTY	DIE No.	DESCRIPTION
1	2	W70223	Clip38 PW3 Pivot Frame
2	2	W70222	Clip38 PW2 Pivot Frame

Hardware

ITEM	QTY	COMPONENT DESCRIPTION
3	8	Self Tapping Screw
4	2	Friction Pivot
5	2	Weephole Cover



This manual must be read in conjunction with the Installation, Cleaning & Maintenance Document and the Performance Certificates for the relevant system. The manual must also be used in conjunction with the design and cutting list from the latest version of StarFront.

Component Assembly Detail

Pivot Sash

Insert finseal before fixing sash frame together

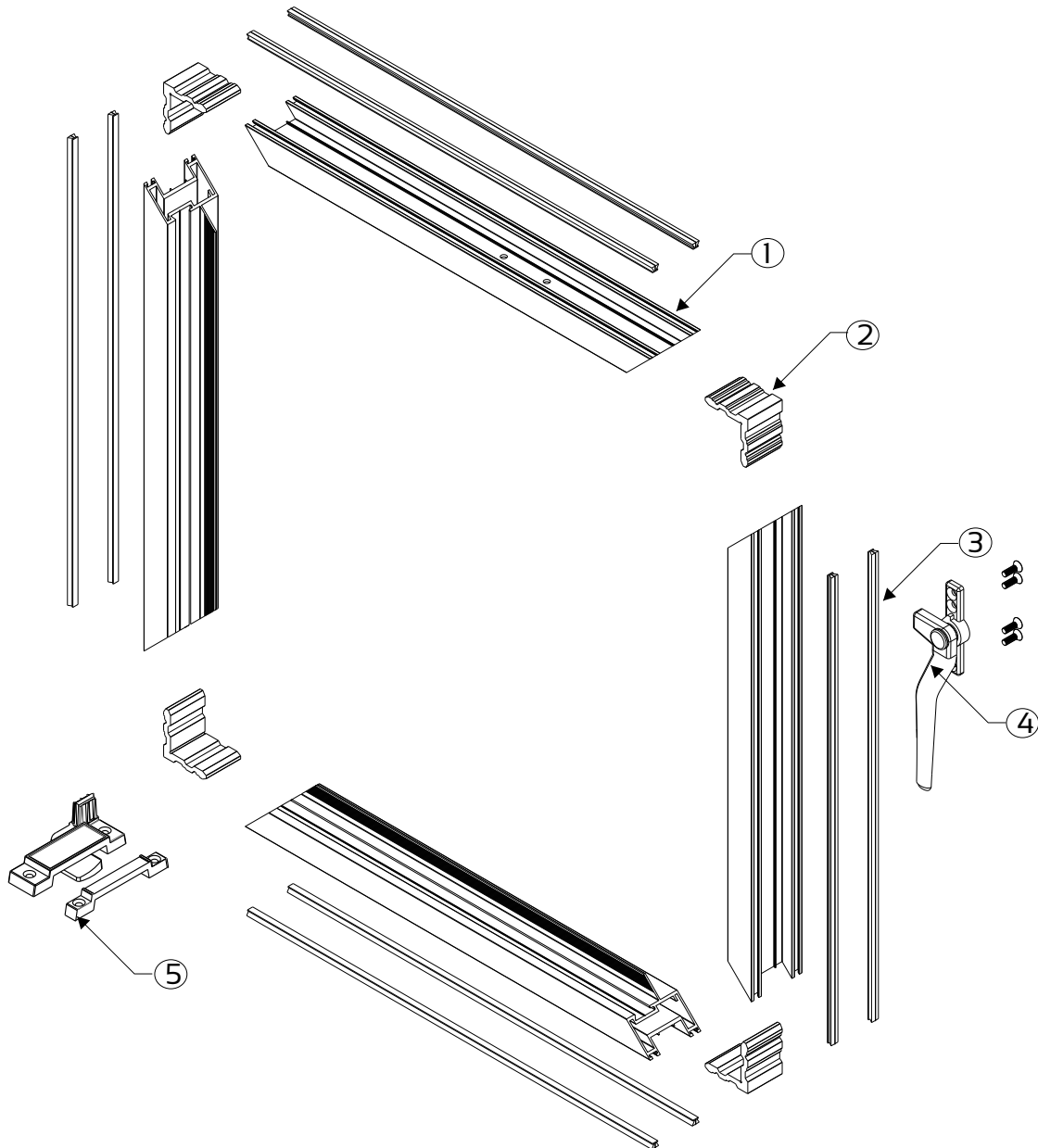

System Profiles

ITEM	QTY	DIE No.	DESCRIPTION
1	4	W54787	Clip38 PWI Pivot Sash

Hardware

ITEM	QTY	COMPONENT DESCRIPTION
2	4	Corner Cleat
3	8	Finseal
4	1	Euroline PT Handle
5	1	Fitch Catch



This manual must be read in conjunction with the Installation, Cleaning & Maintenance Document and the Performance Certificates for the relevant system. The manual must also be used in conjunction with the design and cutting list from the latest version of StarFront.

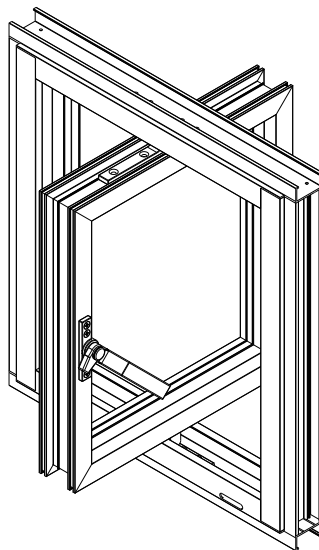
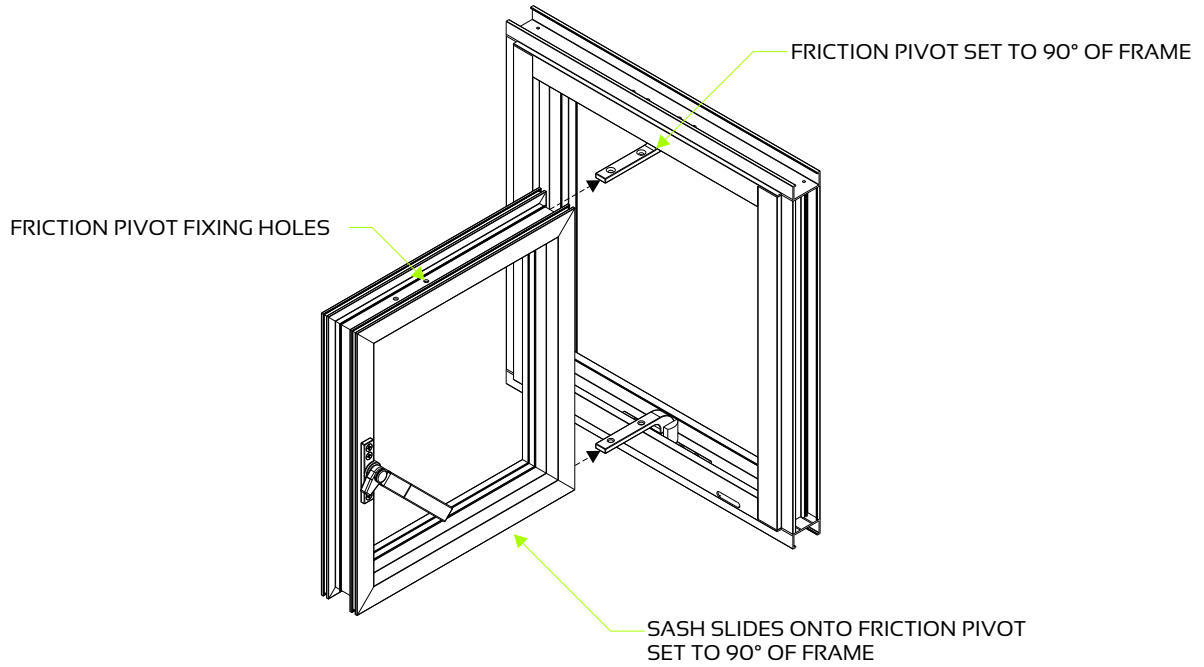

Siliconing Seal of Finseal

on Corners of Pivot Sash

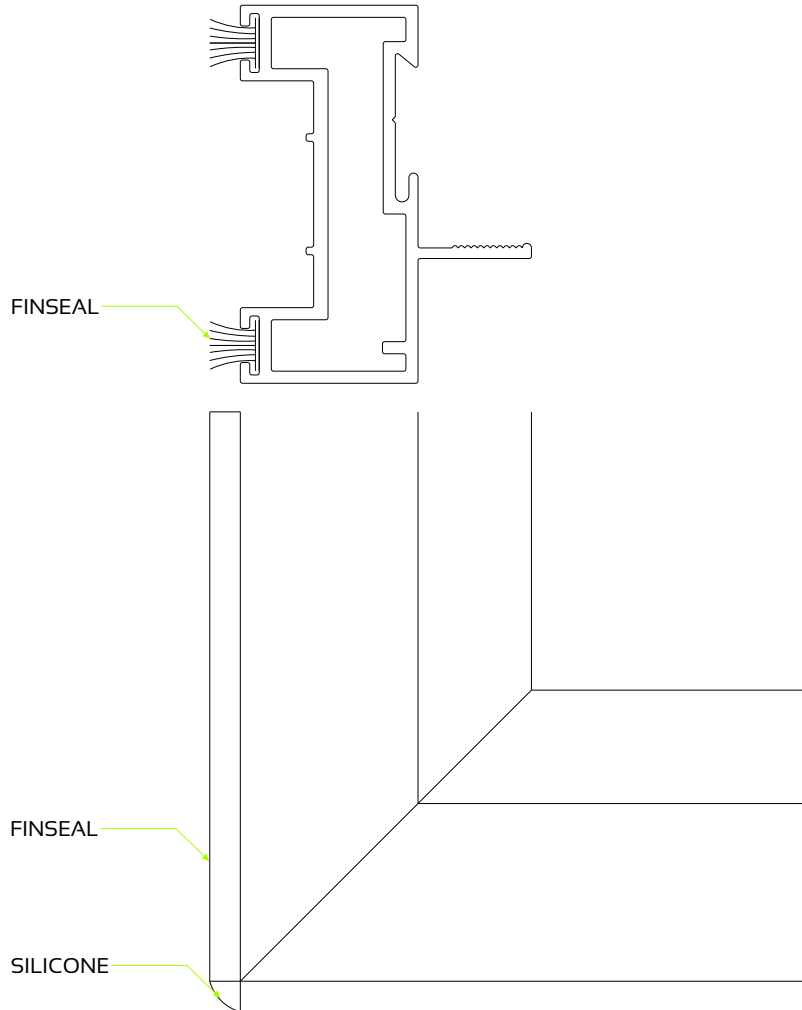

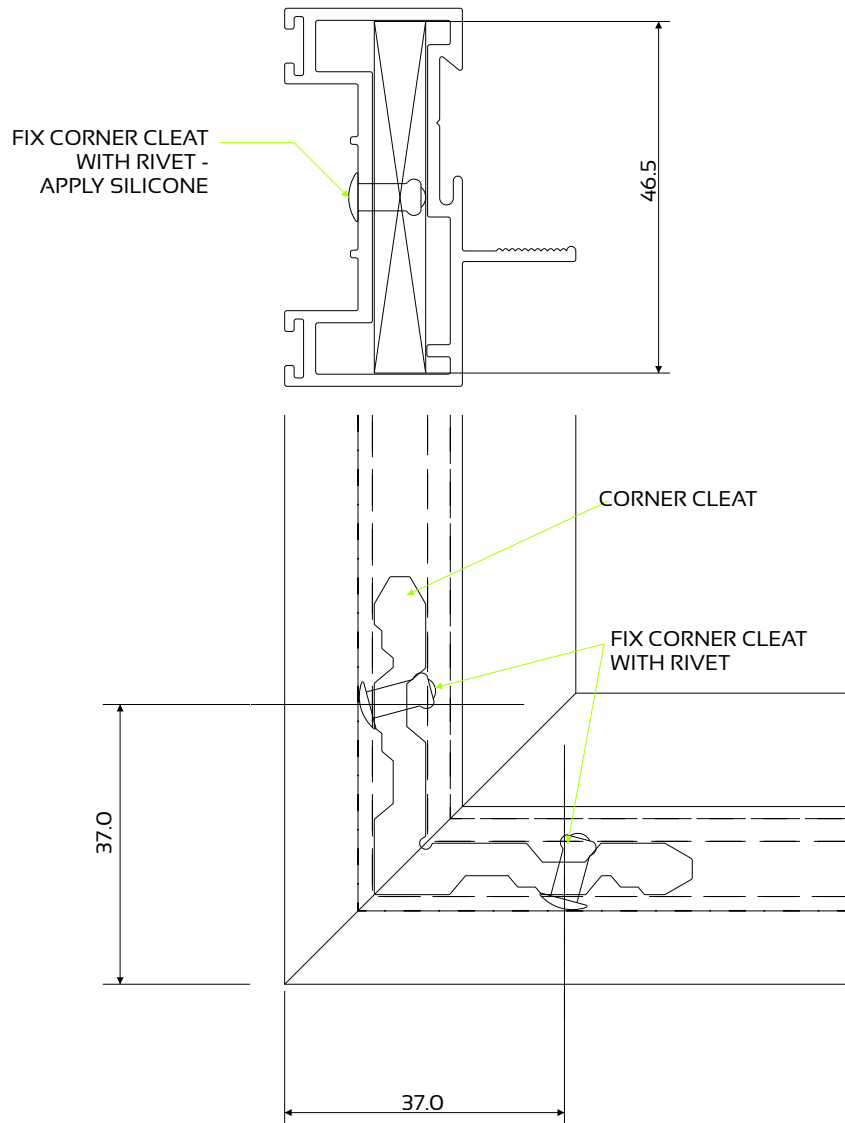

Sill

Add centre drainage hole and covers for sashes over 700mm wide
Note: Check drainage covers will suit slotted holes

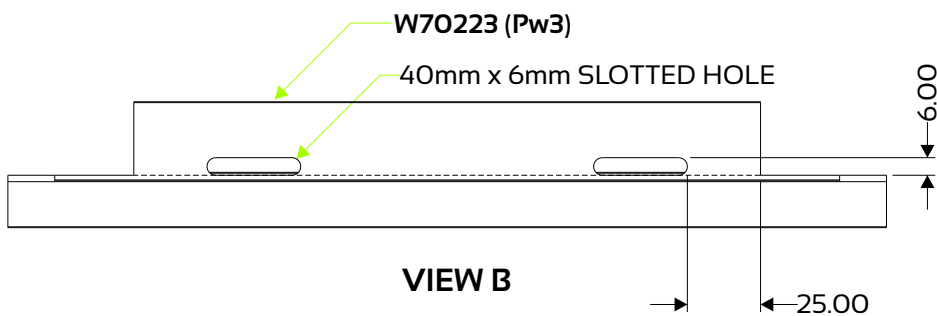
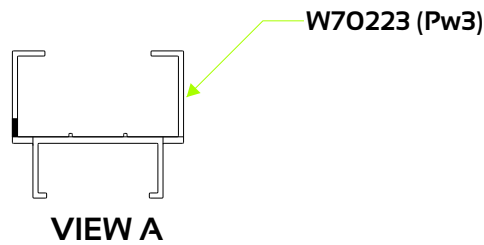
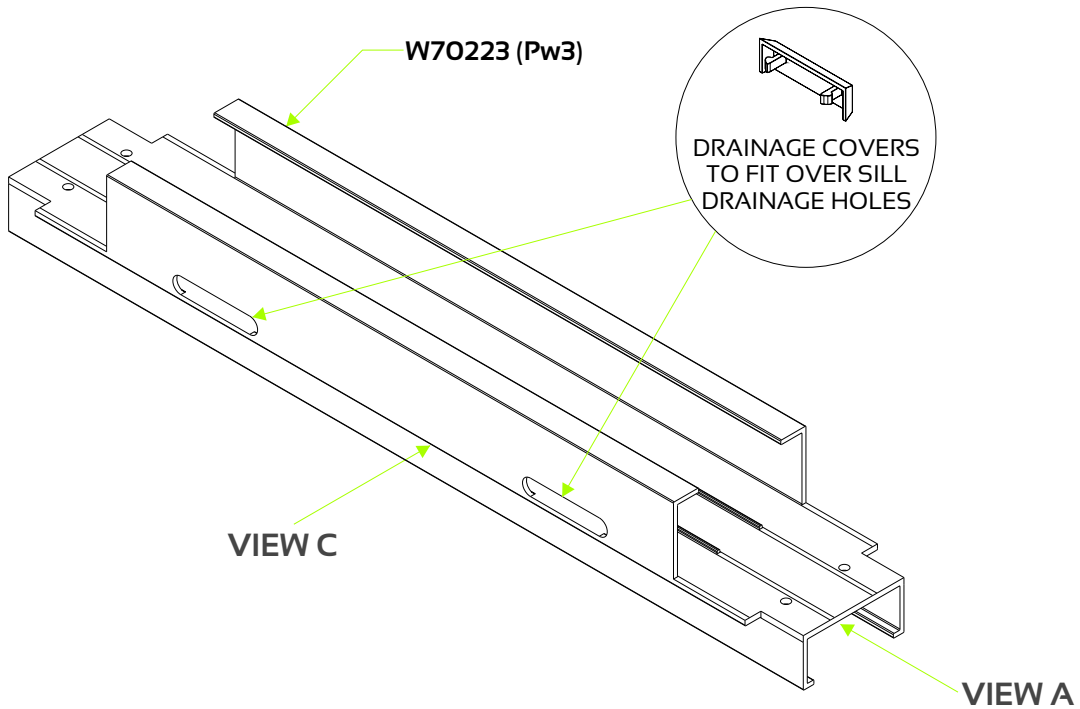

Add centre drainage hole and covers for sashes over 700mm wide
Note: Check drainage covers will suit slotted holes

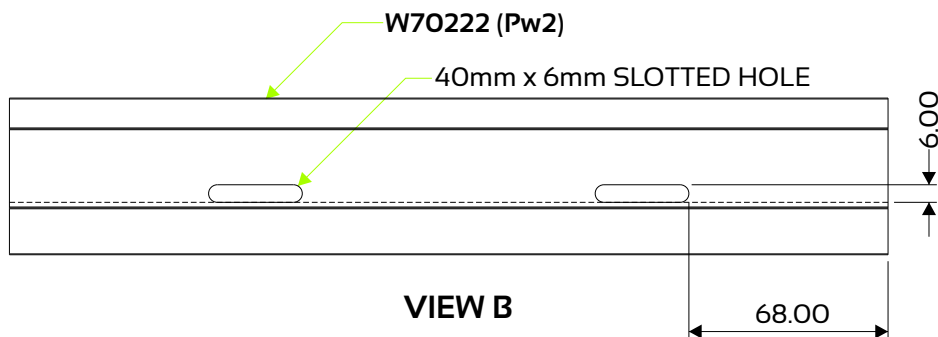
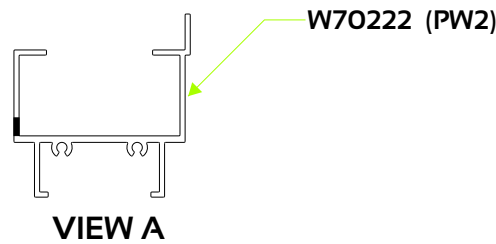
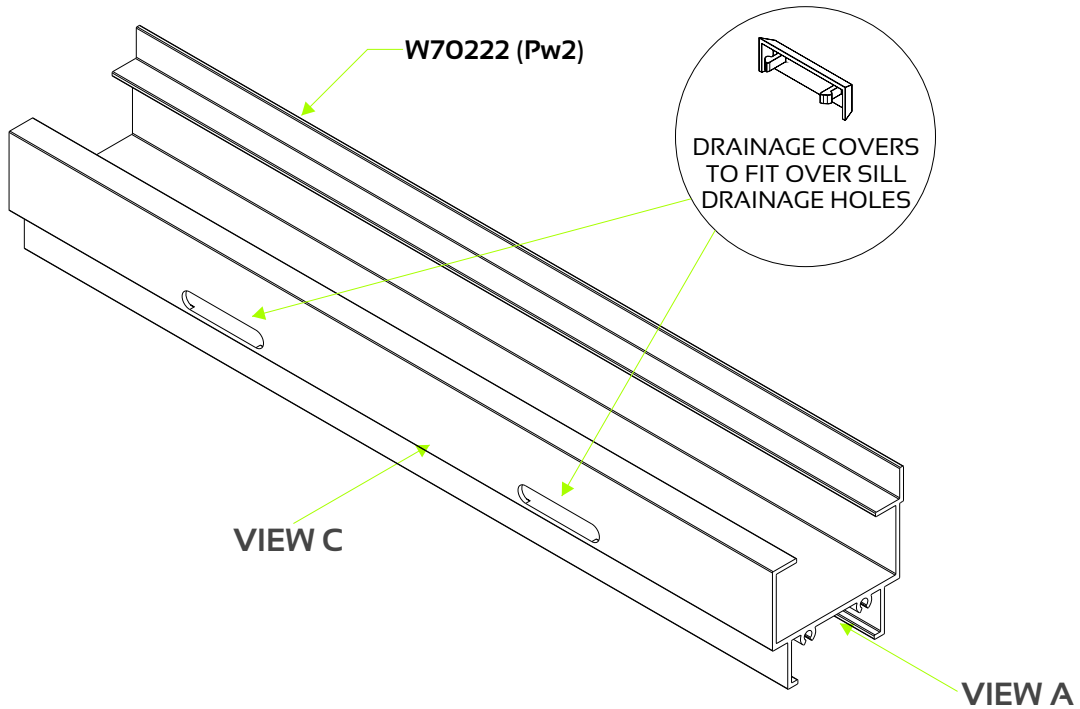

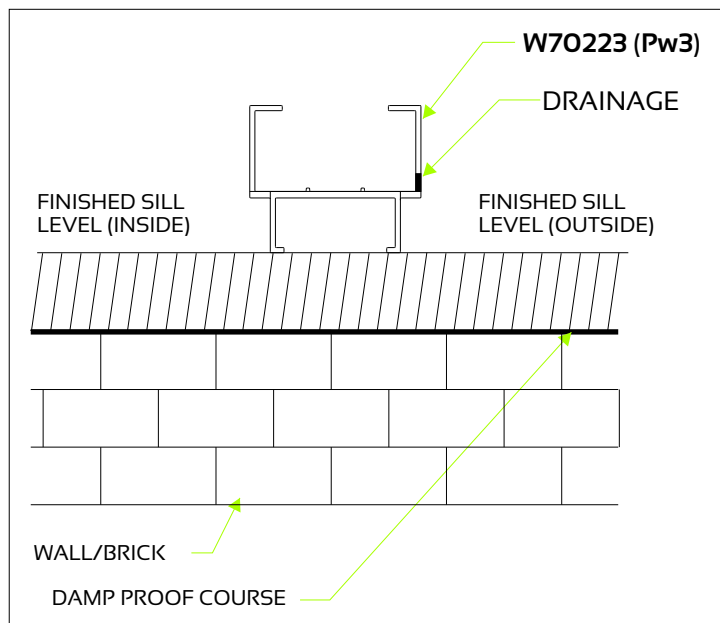
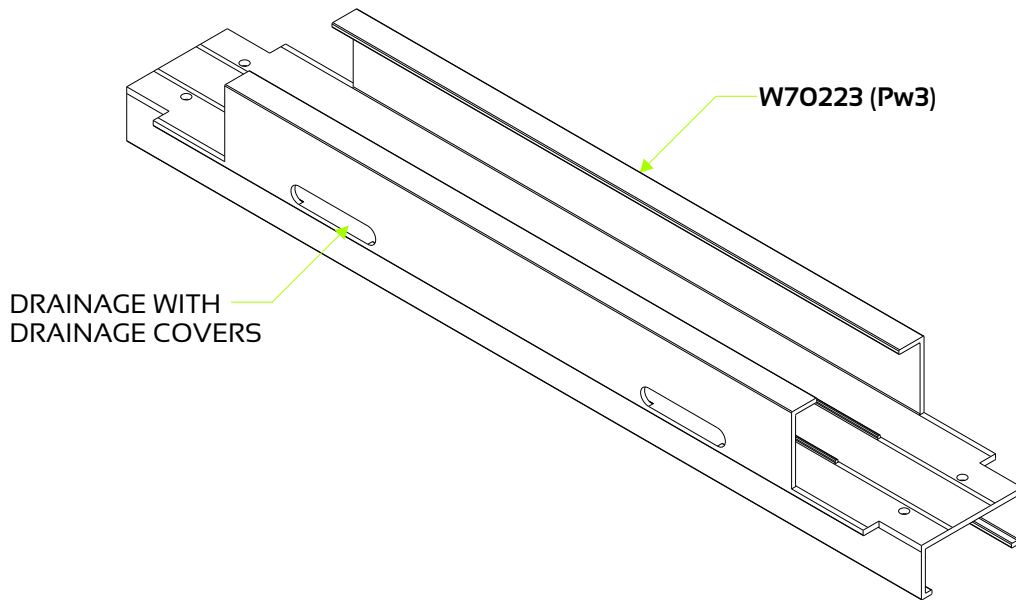

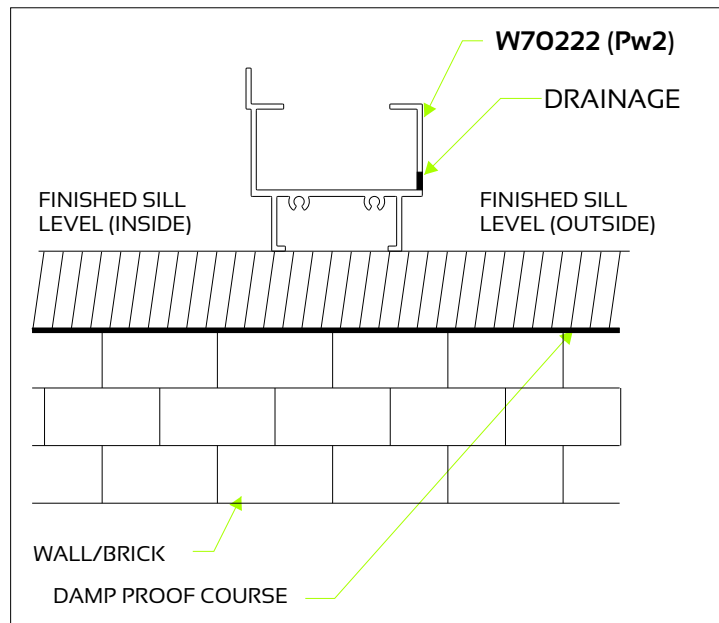
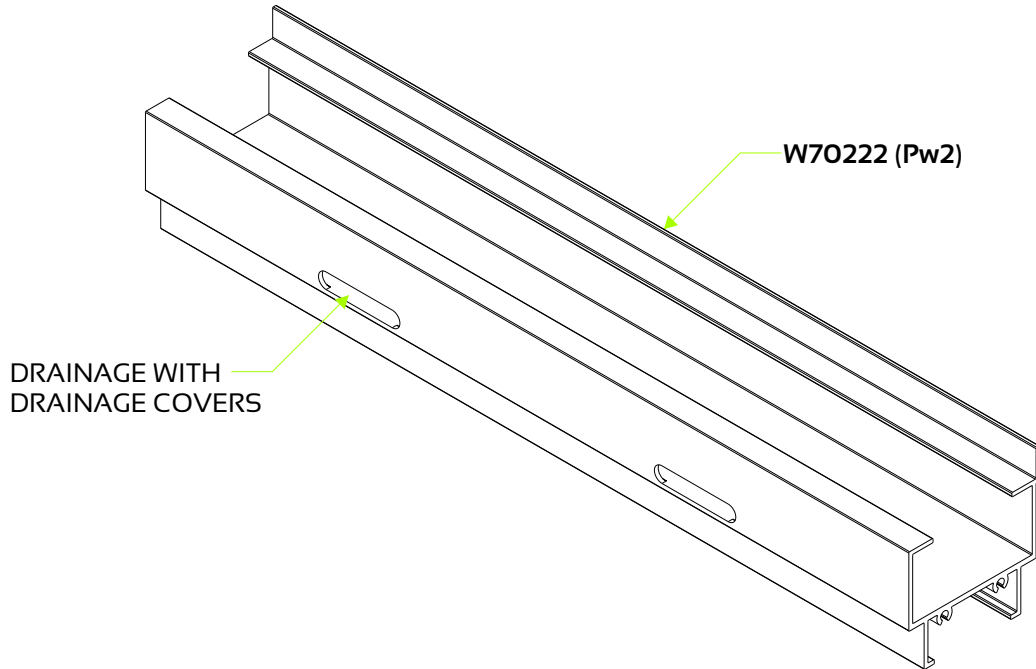

All mechanical joints to be sealed with silicone

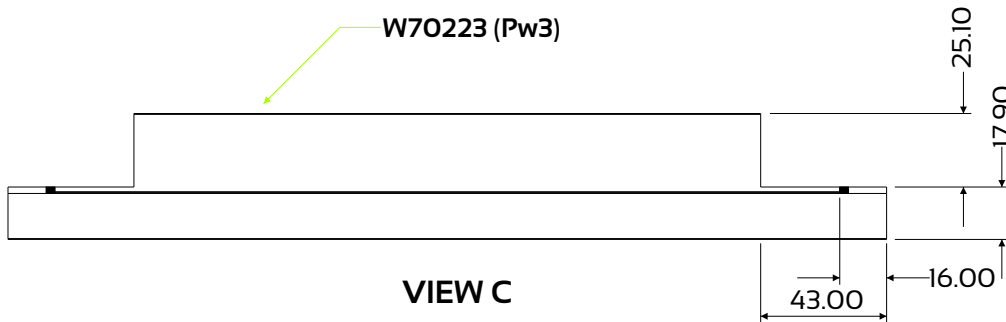
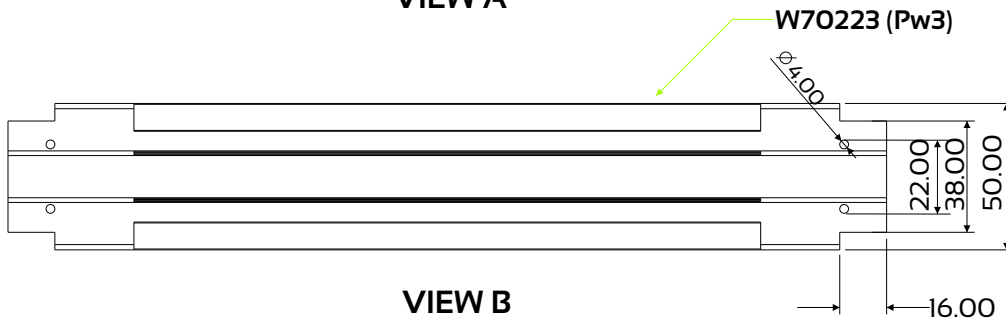
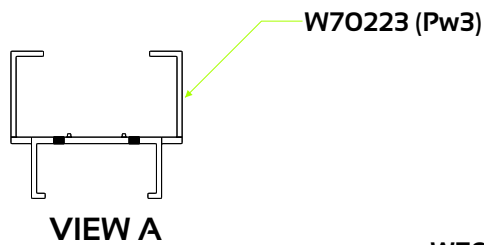
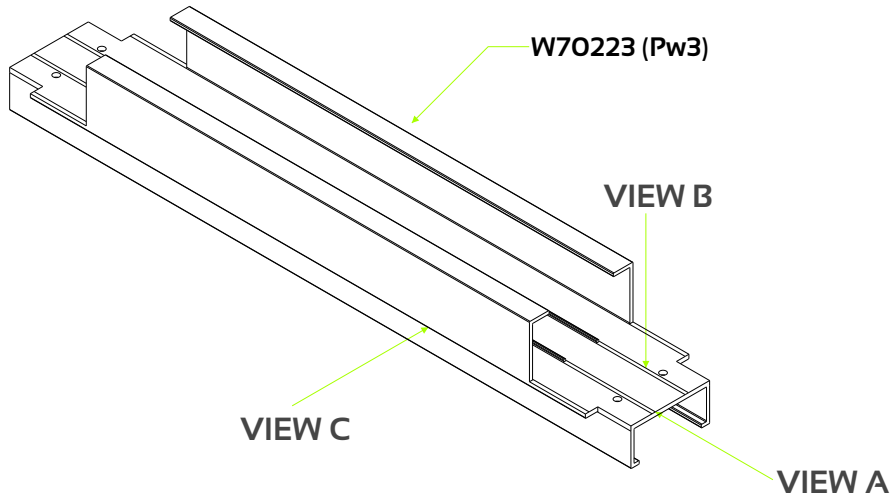

This manual must be read in conjunction with the Installation, Cleaning & Maintenance Document and the Performance Certificates for the relevant system. The manual must also be used in conjunction with the design and cutting list from the latest version of StarFront.

Machining Detail

Frame Friction

Note: Check hole sizes before drilling as these could change.

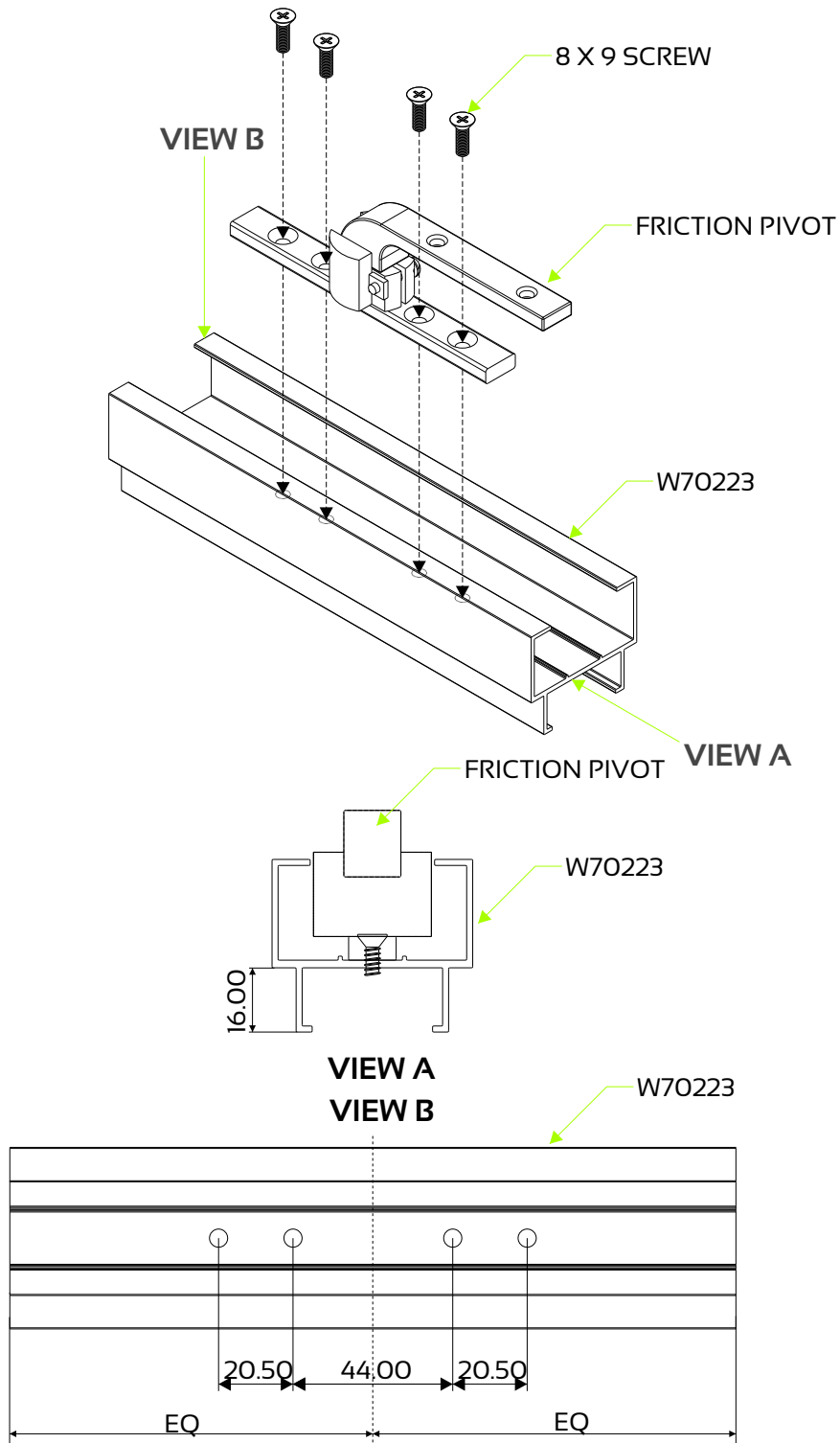

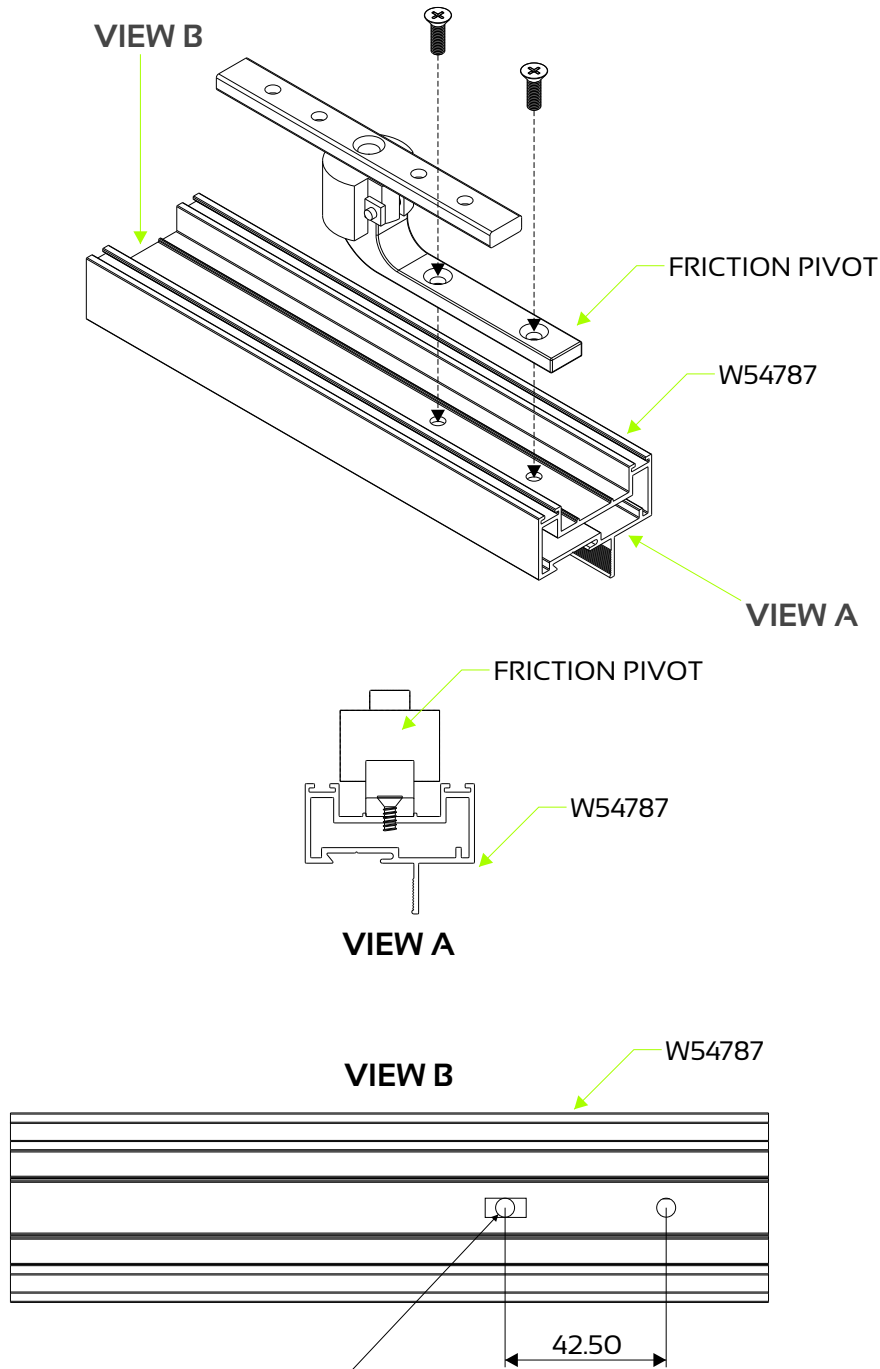

TIP: TO ENSURE THE SASH FITS SQUARELY INTO THE FRAME, DRILL 1 x SLOTTED HOLE TO ALLOW FOR ADJUSTMENT. ONCE SASH FITS SQUARELY, THEN DRILL THE 2nd HOLE.

Machining Detail

Pivot Sash Handle

Must fix wedge (HHWSPFG/HHBSPFG) to frame for PT Handle, recommended to fit 2 handles if sash is wider/higher than 900mm

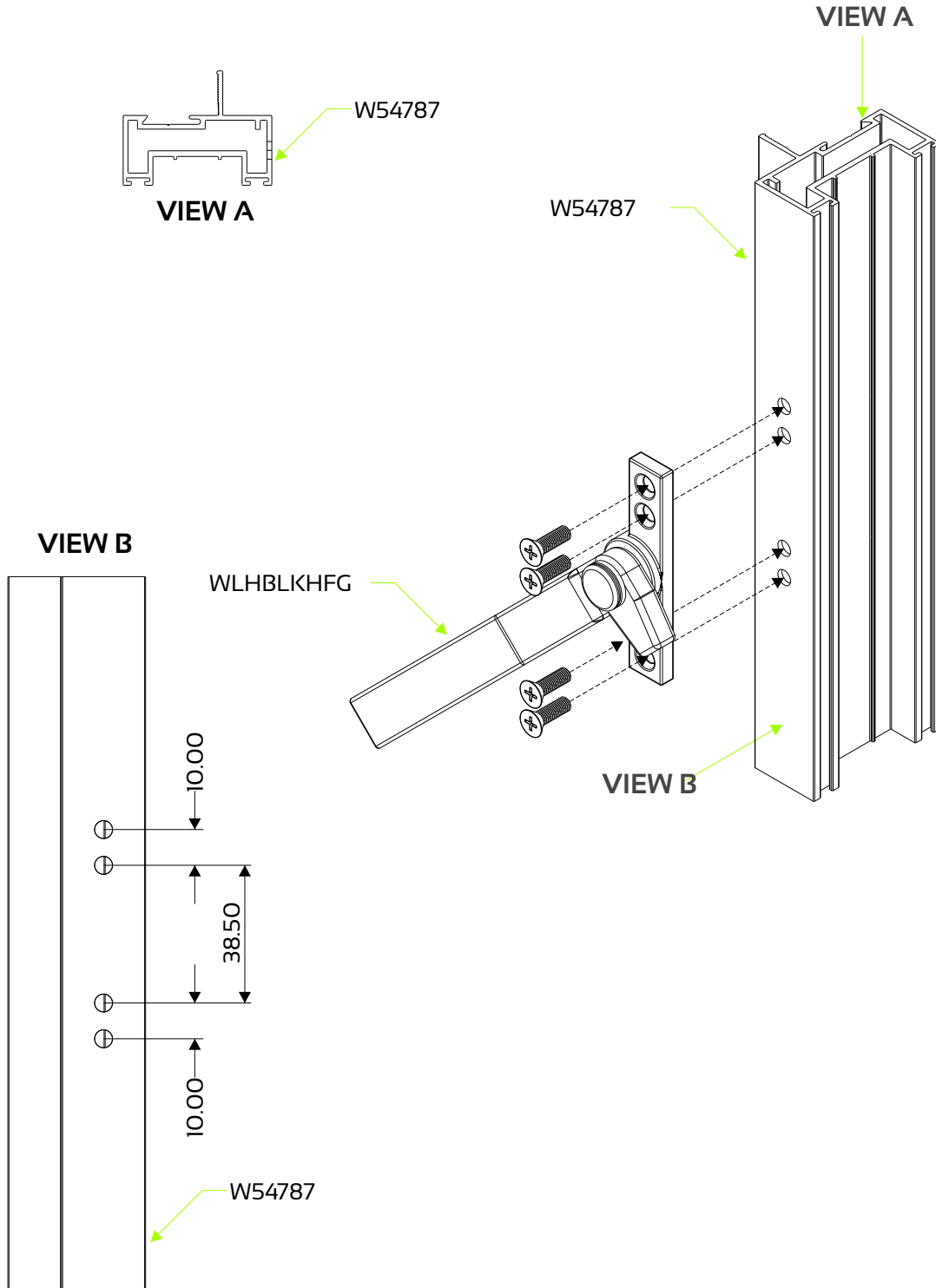

Insert the pull-in vinyl gasket into glazing beads by sliding or pressing it into the groove (1). Before cutting gasket, ensure that it has not stretched and cut 6mm longer so that corners are in compression at all times.

Position bottom glazing bead in glazing bead rebate (2).

Place glass on glazing blocks (3).

Insert top and then side glazing beads ensuring that they are in correctly.

Starting from top centre, insert roll in gasket (4) without stretching it (5). Stop 150mm from corner and partly cut gasket 6mm longer than the edge of the vertical bead. Insert gasket at corner and then roll in remaining 150mm. Repeat this on the other sides. Where gasket ends meet, cut gasket 6mm longer. Insert cut ends first and complete.

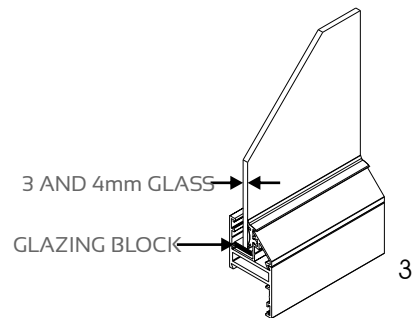
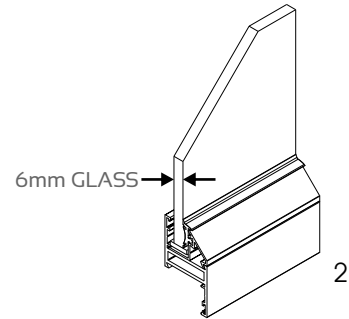
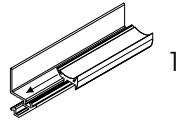

ENSURE GASKETS ARE NOT STRETCHED AT ANY STAGE

TOP
SEEN FROM THE INSIDE

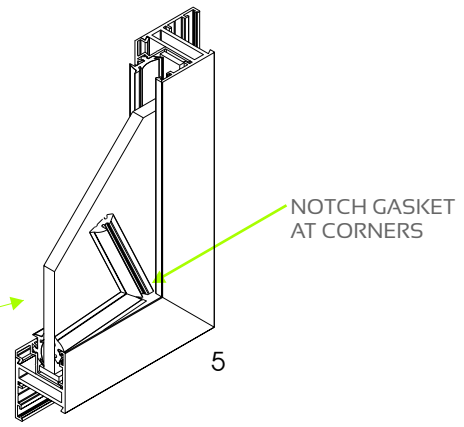
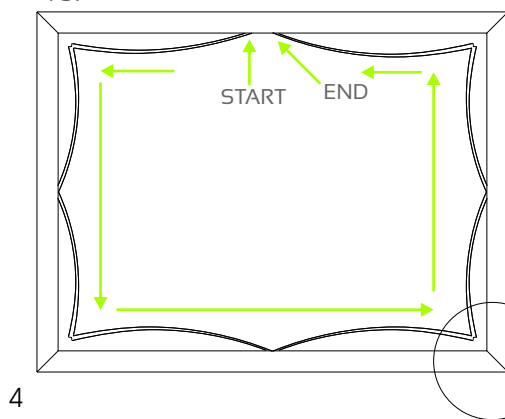

GLAZING

1. SELECTION OF GLAZING METHODS

1.1 SETTING AND LOCATION BLOCKS

Glass-to-metal contact must be avoided at all times by using setting and location blocks having a hardness of 50° to 90° shore A durometer. Use only blocks made of Neoprene, EPDM, Silicone or other elastomeric material.

Setting blocks are to have a minimum thickness of 3mm and must be at least 27mm in length per square metre of glass area.

The position of the setting and location blocks is illustrated in Figure 2.

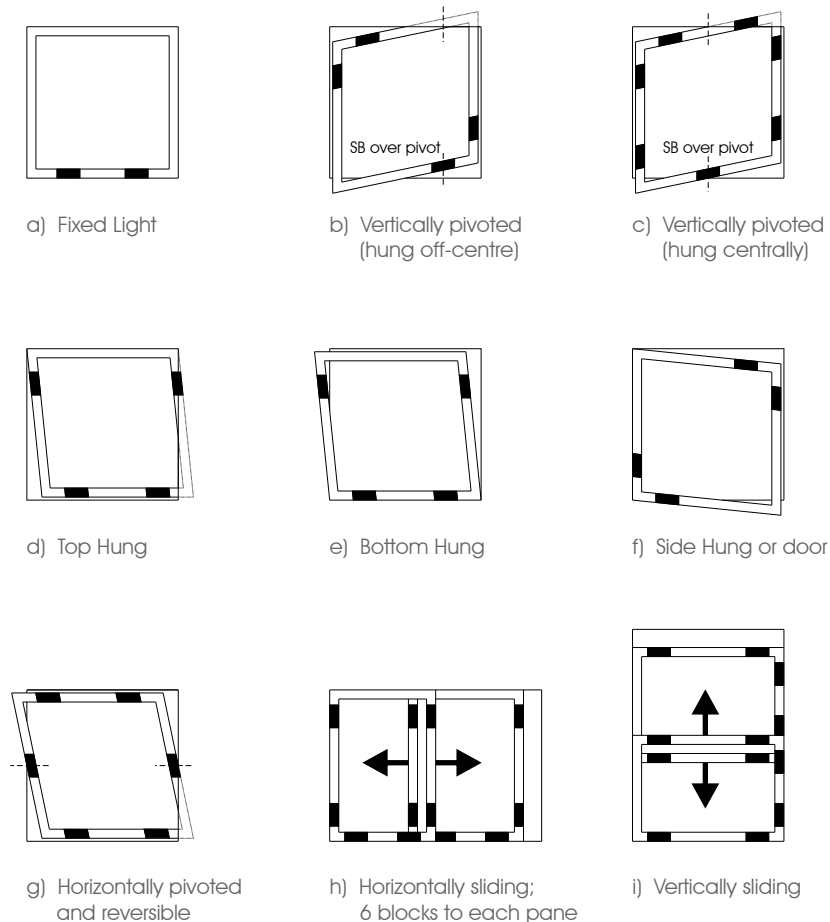

FIGURE 2 - POSITION OF SETTING AND LOCATION BLOCKS